



## Aertek AirTap



Aertek AirTap is one of a suite of 3 over-sink automatic taps, includes water and soap taps

- ADA/DDA Compliant
- High speed, Low Energy
- Low noise 58-63dB
- Digitally adjustable sensing range
- Deck or wall mounted configuration
- Satin S/Steel or available as Black and Brass/Gold

## Technical Specifications

Warranty	3 Years
Green rating	4.1
Drying time (seconds)	10-12 seconds
Peak Noise level (dB)	64dB
Power (Watts)	1000 Watts- 500 Watts-
Voltage	220-240V 50/60 Hz
IP rating	IP35
Air speed (mph)	225
Hygiene Features	
Antimicrobial coating	None
Width (mm)	38
Height (mm)	170
Projection/Depth (mm)	220
Finishes available	Stainless Steel : Satin/Brushed
Aperture Type	Tap
Automatic / Manual	Automatic
External Switch	No
Heating Element	Yes
Max Air Volume (m3/hr)	
Max Motor Speed (rpm)	30000
Standby Wattage (Watts)	0.5

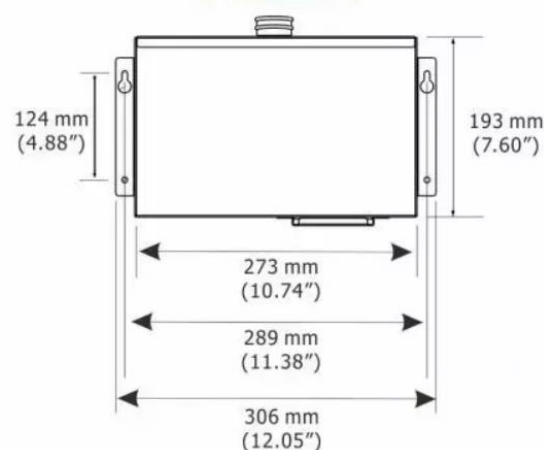
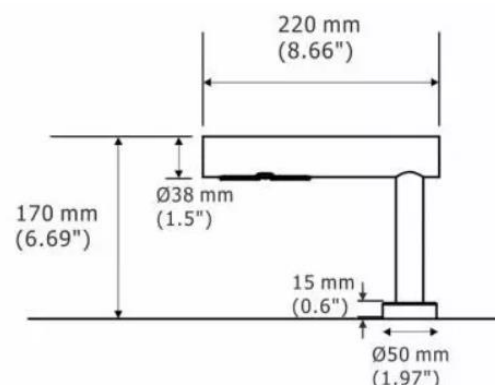



Aertek AutoTap



## NBS BIM Data

NBS Code – **45-35-72 / 334 Hand dryers**  
N13 Sanitary appliances and fittings  
**472 HAND DRYERS**  
Uniclass 2015 – Pr\_40\_20\_62\_37 Hand dryers

## AERTEK AIRTAP HAND DRYER – DECK-MOUNTED

Manufacturer and reference: **Aertek AirTap**  
o3 group ltd, Forsyth House, Belfast, BT2 8LA  
W: [www.o3group.uk](http://www.o3group.uk)  
Contact: Colin O'Hare  
E: [mail@o3group.uk](mailto:mail@o3group.uk)  
Tel: +44 28 9065 6552

Product Reference: **Aertek AirTap T1 High Speed Tap Hand Dryer – Deck-mounted**  
Model Number : **AHD-AJT1**  
<https://www.ehanddryers.com/aertek-air-tap-t1-wash-dry-ecotap>

**Description:** High speed, Low energy, Tap Hand Dryer – Deck Mounted

**Body:** Stainless Steel 304

**Finish:** Satin/Brushed Stainless Steel

**Operation:** Sensor IR Barrier, digitally adjustable range

**Hand Dryer Type:** Hands-under Tap Hand Dryer

**Drying Time:** 12 Seconds

**Noise:** 59.2-63.8dB

**Power:** 1000W – 500W adjustable

**Standby Power:** 0.4W

**Electricity Supply:** 220-240V AC 50/60Hz

**Electrical Protection:** IP35

**Air Speed:** 224mph

**Motor Speed:** 30,000rpm

**Production:** Taiwan Manufactured

**Dimensions(WxHxD):** 38x170x220(mm)

**Warranty:** 3 Year

### Accessories:

SoapTap (Sensor Soap Dispenser)

AutoTap (Sensor Water Faucet)





## Aertek AirTap



## NBS BIM Data

NBS Code – **45-35-72 / 334 Hand dryers**  
 N13 Sanitary appliances and fittings  
**472 HAND DRYERS**  
 Uniclass 2015 – Pr\_40\_20\_62\_37 Hand dryers

## AERTEK AIRTAP HAND DRYER – WALL-MOUNTED

Manufacturer and reference: **Aertek AirTap**  
 o3 group ltd, Forsyth House, Belfast, BT2 8LA  
 W: [www.o3group.uk](http://www.o3group.uk)  
 Contact: Colin O'Hare  
 E: [mail@o3group.uk](mailto:mail@o3group.uk)  
 Tel: +44 28 9065 6552

Product Reference: **Aertek AirTap T2 High Speed Tap Hand Dryer – Wall-mounted**  
 Model Number : **AHD-AJT2**  
<https://www.ehanddryers.com/aertek-air-tap-hand-dryer-t2-wash-dry-ecotap>

**Description:** High speed, Low energy, Tap Hand Dryer – Wall Mounted

**Body:** Stainless Steel 304

**Finish:** Satin/Brushed Stainless Steel

**Operation:** Sensor IR Barrier, digitally adjustable range

**Hand Dryer Type:** Hands-under Tap Hand Dryer

**Drying Time:** 12 Seconds

**Noise:** 59.2-63.8dB

**Power:** 1000W – 500W adjustable

**Standby Power:** 0.4W

**Electricity Supply:** 220-240V AC 50/60Hz

**Electrical Protection:** IP35

**Air Speed:** 224mph

**Motor Speed:** 30,000rpm

**Production:** Taiwan Manufactured

**Dimensions(WxHxD):** 38x170x220(mm)

**Warranty:** 3 Year

### Accessories:

SoapTap (Sensor Soap Dispenser)

AutoTap (Sensor Water Faucet)

